



STAR LONG BAY[®] SYSTEM

YOUR CLEAR-SPAN
BUILDING SOLUTION





YOUR WIDE-SPAN SOLUTION FOR UNOBSTRUCTED, COLUMN-FREE SPACES

FEATURES

- Offered in bays up to 70 feet
- Bolted end seat attachments
- Stable and easy clip attachment
- Stiffer and lighter than a traditional bar joist
- Less bridging than a traditional bar joist
- Fabricated from light-gauge cold-rolled steel with a 4" chord width and 5" seat depth
- Compatibility with standing seam metal roof systems, B Deck, Built-Up, Single-Ply and Multi-Ply roofing systems

BENEFITS

- Cost savings from reduced foundation expense and ease-of-erection
- Fewer footings and interior columns
- Compatible with multiple wall and roofing systems
- Easy to handle, maneuver and erect with no warp or sweep
- Panels attached using self-drilling screws with the ability to bolt to mainframe (no field welding required)
- Perfect solution for manufacturing, warehouse, distribution and large retail applications
- Interfaces with load-bearing masonry or tilt-wall construction and offers faster, more precise installation
- Open web truss secondary framing, delivering roof support and shortening the installation of mechanical and electrical systems

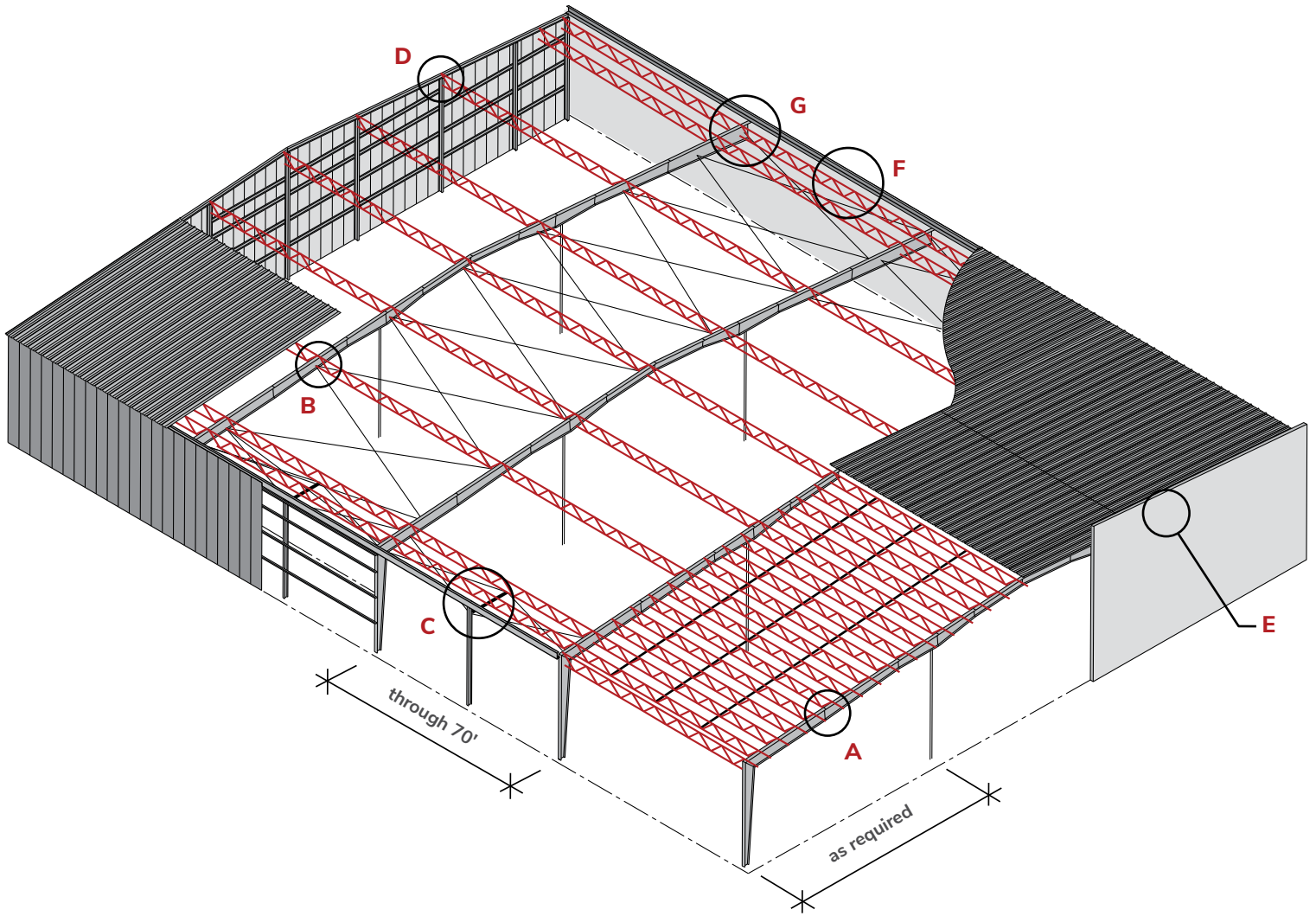

A. STARTING RAKE TRIM

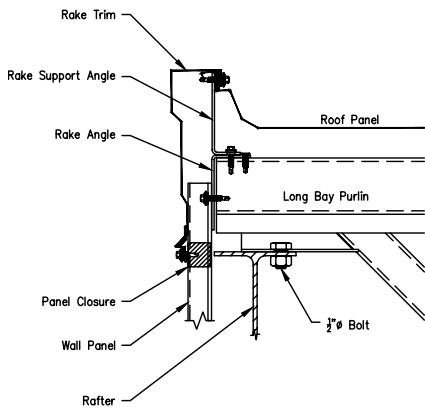

B. FLANGE BRACE CONNECTION

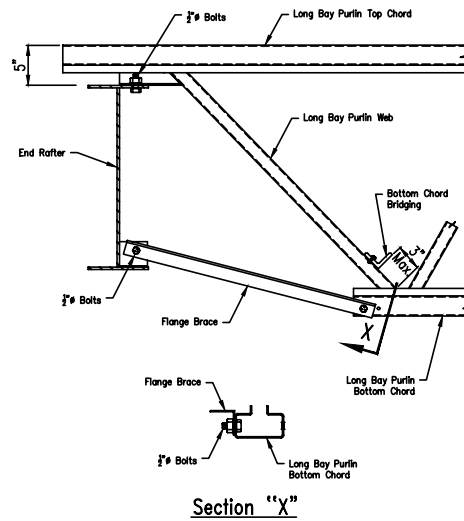

C. LONG BAY WIND STRUT

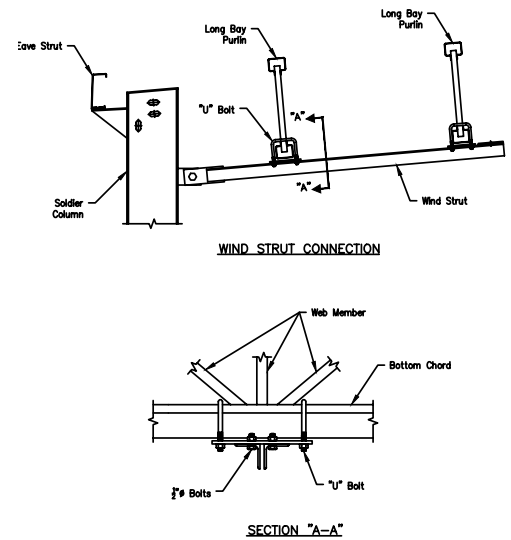

STAR LONG BAY[®] SYSTEM

For enlarged standard details, please access our Searchlight library.

D. RAKE END TRIM

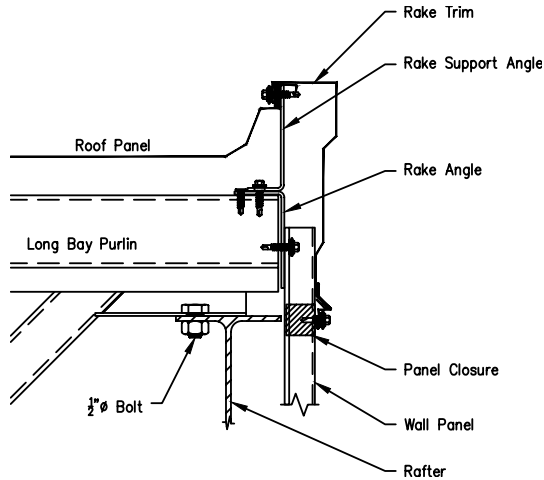

E. LONG BAY PURLIN

Masonry Parapet at Endwall with Ledger Angle

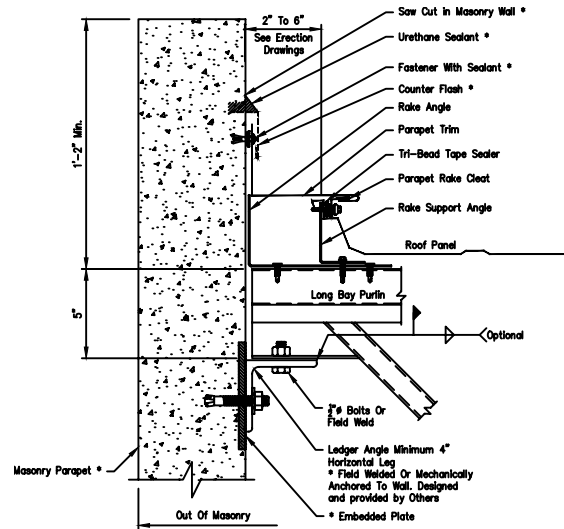

* - Material And Design Is Not By The Metal Building Mfr.

F. LONG BAY PURLIN

Low Side Masonry Wall with Spandrel

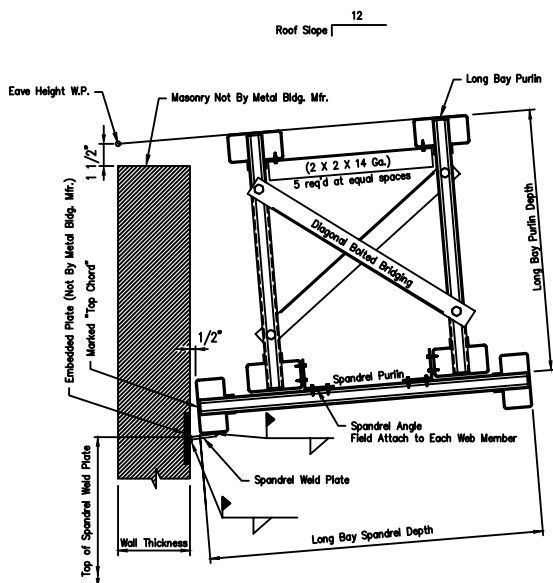

G. LONG BAY PURLIN

Main Rafter to Low Side Masonry Wall with Spandrel Purlin

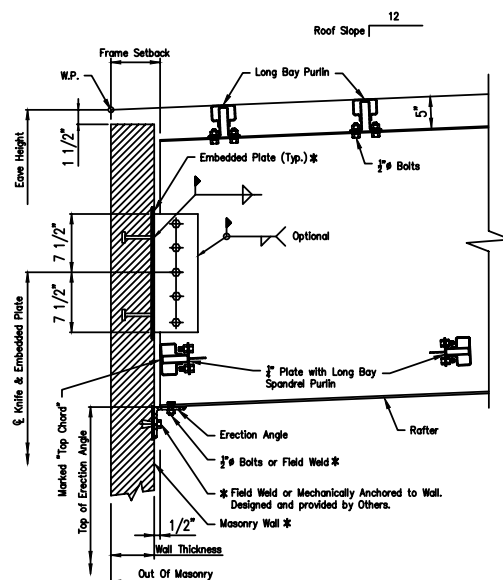

* Not By Metal Building Manufacturer

CUSTOM-ENGINEERED SOLUTIONS FOR VERSATILE BAY SPACING

Star's patented Long Bay® System (LBS) is the ideal solution for projects requiring large areas of space with an open floor design, delivering uninterrupted space while allowing for ample architectural design flexibility.

The Long Bay System utilizes open web truss secondary framing, delivering roof support and shortening the installation time for mechanical and electrical systems. Compatible with multiple wall and roofing systems, Long Bay provides you with additional flexibility in construction design. Long Bay is also perfectly suited for manufacturing, distribution and large retail applications.

The single-source design, fabrication and schedule control eliminates inconsistencies and interruptions during the entire building design and erection process. Additionally, Long Bay purlins are bolted to the rafter rather than welded, requiring 50% less horizontal bridging than a bar joist. Horizontal bridging is attached with self-drilling screws instead of welding as with a typical bar joist. Bolting also allows the erector to connect materials together on the ground and lift in sections during installation. This produces substantial labor cost savings, improves on-site safety and increases speed to market.

Long Bay is offered in bays from 40' to 70'. It is flexible in design with less bridging, can bolt to the main frame and is stiffer and lighter than a traditional bar joist. Long Bay interfaces with load-bearing masonry or tilt-wall construction and offers a faster, more precise installation. It is easy to handle, maneuver and erect with no warp or sweep.





At Star, we are relentlessly committed to our customers and to creating great building solutions that enable communities to grow and thrive.

LET US HELP YOU BECOME A LEADER IN THE METAL BUILDING INDUSTRY. CONTACT US TODAY:

1-800-879-7827 ■ HELLO@STARBUILDINGS.COM ■ STARBUILDINGS.COM

Descriptions and specifications contained herein were in effect at the time this publication was approved for printing. In a continuing effort to refine and improve products, Star Building Systems reserves the right to discontinue products at any time or change specifications and/or designs without incurring obligation. To ensure you have the latest information available, please inquire or visit our website at www.starbuildings.com.

©2020 Star Building Systems, Part of the Cornerstone Building Brands Family. All Rights Reserved.

0409209991102/EBS/CG/0920

