

Flush Transverse Partition - Type 4 Connection

Bolted F.O. Jamb/Sub-Jamb at Slope - Field and Factory Located

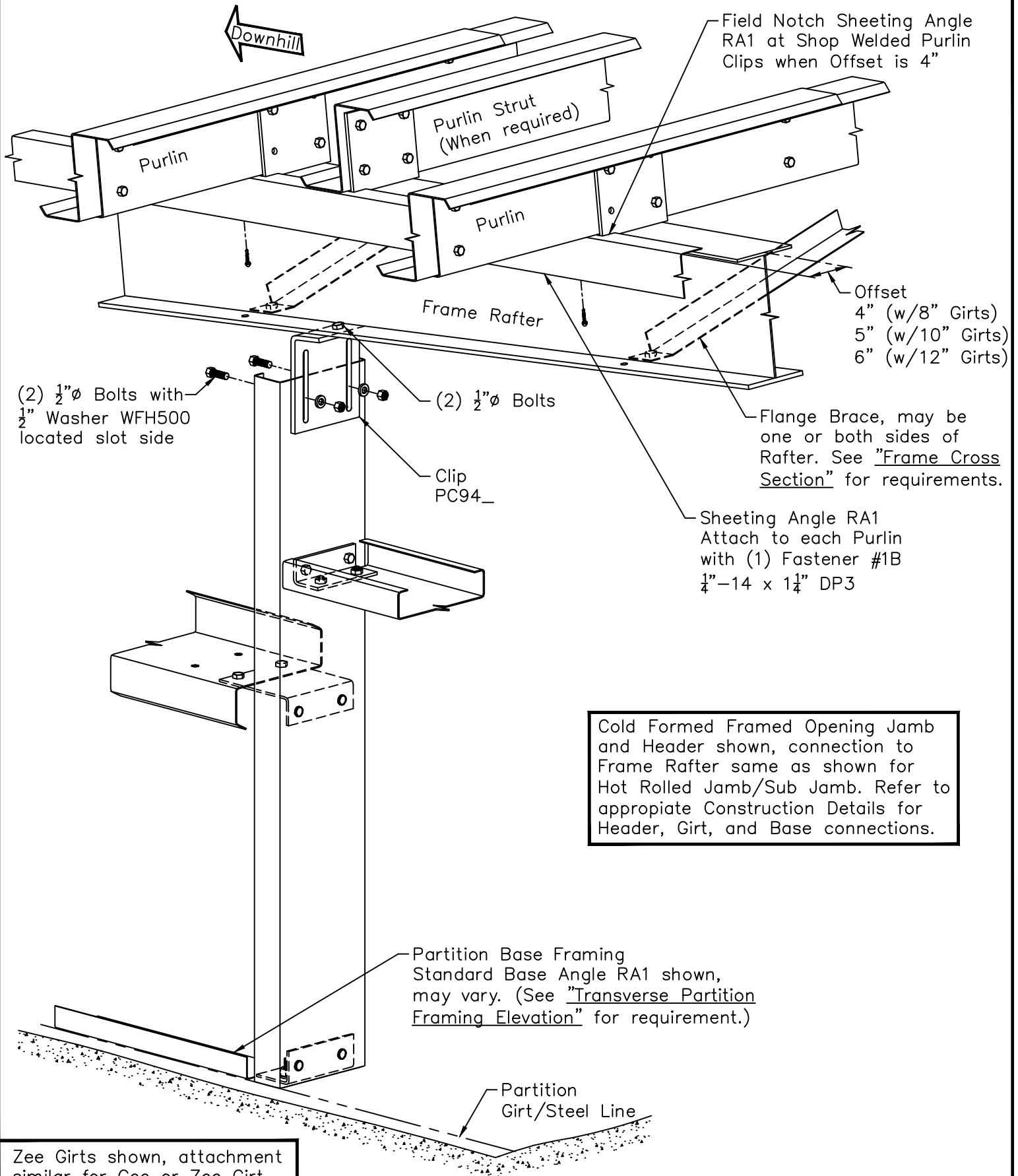

(2) 1/2" ϕ Bolts with 1/2" Washer WFH500 located slot side

(2) 1/2" ϕ Bolts

Clip PC94_

Field Notch Sheeting Angle RA1 at Shop Welded Purlin Clips when Offset is 4"

Offset
 4" (w/8" Girts)
 5" (w/10" Girts)
 6" (w/12" Girts)

Flange Brace, may be one or both sides of Rafter. See "Frame Cross Section" for requirements.

Sheeting Angle RA1 Attach to each Purlin with (1) Fastener #1B 1/4"-14 x 1 1/2" DP3

Cold Formed Framed Opening Jamb and Header shown, connection to Frame Rafter same as shown for Hot Rolled Jamb/Sub Jamb. Refer to appropriate Construction Details for Header, Girt, and Base connections.

Partition Base Framing Standard Base Angle RA1 shown, may vary. (See "Transverse Partition Framing Elevation" for requirement.)

Partition Girt/Steel Line

Zee Girts shown, attachment similar for Cee or Zee Girt with outer flange toed up.