

# Maintenance Manual

For



Star Building Systems

**STAR BUILDER:** \_\_\_\_\_

(NAME)

\_\_\_\_\_  
(ADDRESS)

\_\_\_\_\_

**OWNER:** \_\_\_\_\_

(NAME)

\_\_\_\_\_  
(ADDRESS)

\_\_\_\_\_

**DATE:** \_\_\_\_\_

# CONTENTS

---

## **Introduction**

### **Section 1 – Periodic Maintenance**

- (A) Accessories
- (B) Roof and Wall Panels
- (C) Structural

### **Section 2 – Paint and Finishes**

- (A) Primer
- (B) Panel Finishes

### **Section 3 – Extending Building Service Life**

- (A) Roof Traffic
- (B) Mechanical Equipment Located on Roof
- (C) Snow Removal
- (D) Traffic Protection
- (E) Condensation
- (F) Additional Loads

# INTRODUCTION

Congratulations! Your selection and investment in a Star Building System is a wise one. Your Star building is manufactured from high-quality material and should provide you with many years of excellent service. Star has been in business since 1927 and has gained valuable expertise in providing the very best in quality and professionalism. Because of this experience, your building design and material are among the best in the industry.

This maintenance manual should provide guidance for maintenance personnel in cleaning and caring for your metal building, in order to prevent problems that could arise from neglect. The information contained within is not intended to cover modifications or repairs. Contact your Star Builder for assistance with any building issues beyond the scope of routine maintenance. The statements contained herein are Star's opinions only and are not affirmations of fact. They are presented without guarantee or responsibility on Star's part and do not present any implied warranty for following suggested maintenance procedures.

## GENERAL SAFETY RECOMMENDATIONS

Always comply with all Federal, State and Local guidelines and OSHA regulations when performing routine building maintenance and or repairs. Always use OSHA approved Fall Protection when working in an elevated place:

- Do not walk on roof flashing such as gutter, rake, hip or ridge flash.
- Do not walk on light transmitting panels (LTP's). They will not support a person's weight.
- Guard all LTP's and roof openings.
- Step only in the panel flat directly on or in close proximity to a supporting roof structural.

**DESCRIPTIONS AND SPECIFICATIONS CONTAINED HEREIN WERE IN EFFECT AT THE TIME THIS PUBLICATION WAS APPROVED FOR PRINTING. IN A CONTINUING EFFORT TO REFINE AND IMPROVE PRODUCTS, THE MANUFACTURER RESERVES THE RIGHT TO DISCONTINUE PRODUCTS AND SERVICES AT ANY TIME OR CHANGE SPECIFICATIONS AND/OR DESIGNS WITHOUT INCURRING OBLIGATION. TO ENSURE YOU HAVE THE LATEST INFORMATION AVAILABLE, PLEASE INQUIRE.**

## SECTION 1 – PERIODIC MAINTENANCE

### A. ACCESSORIES

#### 1. GUTTERS

Gutters should be inspected and cleaned annually using a water hose with good pressure to flush dirt and small debris. Larger items, such as rocks, cans, etc., should be removed by hand. The sheet metal edges of the gutter and roof may cause cuts to hands and arms. Always wear proper protective clothing.

Gutter obstructions can cause dirt build up. Dirt build up holds moisture, causing premature rusting and allowing water to overflow. This can result in a leak at the eave trim to roof panel seal. Blocked downspouts can produce the same results if not free to drain.

Added weight from dirt buildup, compounded with weight from ice and snow, could add unnecessary stress and possibly result in damage to the gutters.

GUTTERS AND/OR EAVE TRIM MAY BE DENTED OR OTHERWISE DAMAGED IF CARE IS NOT USED IN PLACING LADDER WHEN CLEANING GUTTER OR DOING OTHER SERVICE WORK ON THE ROOF.

#### 2. WALK DOORS

Walk doors must be checked and serviced as required. A routine check should include:

- Check for tightness of locksets, closure hardware and hinges.
- Check for and repair any loose fasteners on all doors.
- Lightly oil mechanical parts including hinges.

### 3. WINDOWS

Windows require very little maintenance. To maintain, lubricate the window track with a light machine oil, clear sill drain holes and inspect screen for tears and replace as required. Inspect the caulking along the window header. Re-caulk if weathertightness is interrupted.

### 4. ALL OPENING HEADERS (Overhead doors, windows, walk doors, louvers, Narrowlites, storefronts, etc.)

Caulking should be inspected for shrinkage or cracking and replaced as required. At the same time, debris should be cleaned out of head flash area to allow proper drainage.

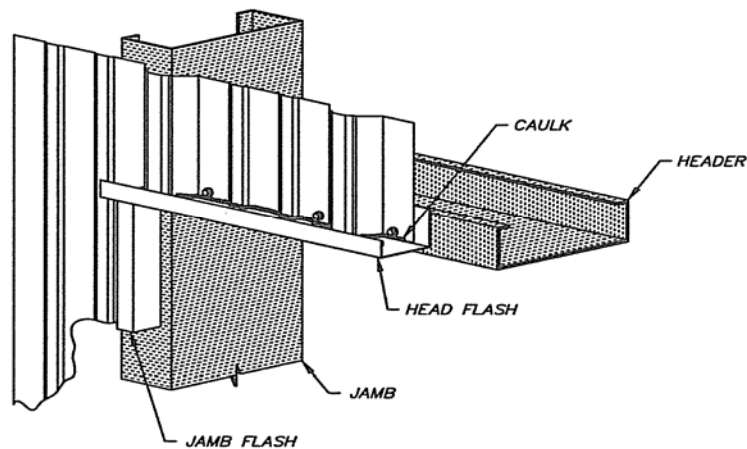

Framed Opening

## B. ROOF AND WALL PANELS

### 1. CLEANING

Star's high-quality finishes maintain their protective value for long periods of time. They will, however, have a tendency to pick up dirt and film deposits over time, and may lose their original appearance if a

proper maintenance procedure is not established for keeping the finishes in prime condition.

THE MOST IMPORTANT CLEANING IS DONE IMMEDIATELY AFTER THE ERECTION OF THE BUILDING, AS METAL SHAVINGS ARE PRESENT AND ARE SOMEWHAT MAGNETIZED BECAUSE OF THE SCREW AND DRILL ROTATION. SHAVINGS ARE NOT ALWAYS VISIBLE AND MUST BE SWEEPED OFF THE ROOF AND WALLS TO PREVENT CORROSION OF THE PARTICLES, WHICH WILL STAIN THE FINISH.

a. Dirt Build-Up

In many cases, simply washing the building with plain water using hoses or pressure sprays will be adequate.

In areas where heavy dirt deposits dull the surface, a solution of water and a mild laundry detergent (1/3 cup per gallon of water) may be used. A soft bristle brush with a long handle may be useful. A clear water rinse should follow.

CAUTION

SOAPY SURFACES SHOULD BE KEPT WET TO AVOID SOAP DRY-OUT WHICH COULD CAUSE STREAKING.

b. Mildew

Mildew may occur in areas subject to high humidity, but is not normally a problem due to the high inherent mildew resistance of the finishes used. However, mildew can grow on dirt and spore deposits in some cases. To remove mildew along with the dirt, the following solution is recommended.

1/3 cup detergent (Tide, for example)

2/3 cup tri-sodium phosphate (soilax for example)

1 quart sodium hypochlorite 5% solution (Clorox, for example)

3 quarts water

- c. Oil, Grease, Tar, Wax, Caulk, Etc., Clean-up  
Most organic solvents are flammable and/or toxic, and must be handled accordingly. Read the manufacturer's Material Safety Data Sheet (MSDS) on any solvent used. Keep away from open flames, sparks and electrical motors. Use adequate ventilation, protective clothing and goggles.

- 1. Alcohols

- a. Denatured Alcohol (ethanol)
- b. Isopropyl (Rubbing Alcohol)

- 2. Solvents

- a. VM&P Naptha
- b. Mineral Spirits
- c. Kerosene
- d. Turpentine (wood or gum spirits)

**PRECAUTIONS: DO NOT USE WIRE BRUSHES, ABRASIVES OR SIMILAR CLEANING TOOLS WHICH WILL MECHANICALLY ABRASE THE COATINGS SURFACE. MISUSE OR ABUSE OF ANY OF THE CLEANING AGENTS LISTED ABOVE WILL RESULT IN A VOIDING OF WARRANTY FOR THE SURFACE AFFECTED. GRAFFITI PRESENTS A SPECIAL PROBLEM BECAUSE OF THE MANY POSSIBLE AGENTS USED, GENERALLY AEROSOL PAINT. IT IS BEST TO TRY SOAP AND WATER FIRST, THEN SOLVENTS. IF NONE OF THESE ARE SATISFACTORY, IT MAY BE NECESSARY TO RESORT TO TOUCHUP, REPAINT OR REPLACEMENT.**

## 2. FASTENERS

Generally, roof and wall panel fasteners will not require a frequent check. However, due to building movement, some may need to be retightened.

Extreme care should be exercised when retightening, because it will be very easy to strip the fastener. If this should occur, the fastener should be removed and replaced with a larger size.

Standard fastener applications for roof will have a sealing washer. Proper fastener engagement and correct washer seating is important to check when retightening. Fasteners must compress the sealant between the lapped panels.

*(CARE MUST BE USED TO  
AVOID STRIPOUT)*

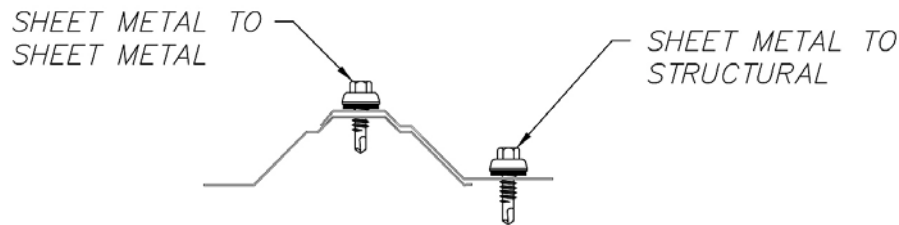

Fastener Conditions

### 3. FOAM CLOSURES

Inspect foam closures for excess weathering or displacement and replace as necessary. Contact your Star Builder for proper foam closure replacement.

## C. STRUCTURAL

### 1. ROOF AND WALL BRACING

If your building is rod braced, the bracing should be inspected to insure it has not stretched or worked loose. Rod bracing will have a certain amount of sag to it even when it is well adjusted. It is advisable to contact your local Star Builder to have a qualified person inspect the bracing and adjust the rods if required. This is particularly important on buildings in which cranes are operating, as the longitudinal forces imposed by the crane are transferred through the rod bracing.

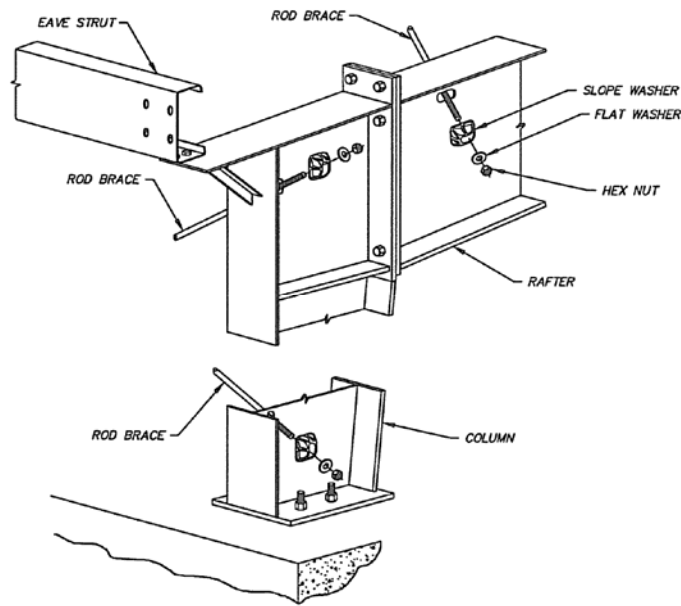

## ROD BRACING

### 2. CRANE RUNWAY BEAMS

The success of the crane support system under service loads depends greatly upon the bolts and nuts used in the assembly and the maintenance after installation. It is important that bolts and nuts meeting ASTM specification A-325 be used. After the runway is installed, the bolts should be retightened within 30 days. The bolts should then be inspected and retightened every three months thereafter. The importance for this bolt-tightening procedure cannot be overemphasized in prolonging the life of a crane runway installation.

## **SECTION 2 – PAINT AND FINISHES**

### **A. PRIMER**

The coat of shop primer is intended to protect the steel framing for only a short period of exposure to ordinary atmospheric conditions. Shop primer does not provide the uniformity of appearance or the durability and corrosion resistance of a field applied finish coat of paint over a shop primer.

## **B. PANEL FINISHES**

Star's standard panel finishes are Siliconized-Polyester (Signature 200) and Kynar (Signature 300). You should refer to specific warranty documents supplied to you with your building for information on guaranteed finish life.

### **1. REPAINTING**

While the high quality paint finishes presently used for pre-painted buildings will maintain their protective properties for many years, and will keep their good appearance if properly maintained, they may eventually require repainting. As the building owner, you may decide to repaint in order to change the exterior color of the building. In this event, it is recommended that the building be properly cleaned, as covered in Section I under roof and wall cleaning, and then painted with an air-dry paint.

The high-quality paint finish originally supplied on the pre-painted material will act as a very high-quality primer, with no difficulty, provided the surface is first properly cleaned and prepared; however, epoxy paints are not recommended over existing finish without special primer.

We suggest that specific paints be discussed with qualified painting contractors and paint suppliers and their recommendations followed.

### **2. SURFACE PREPARATION FOR PRE-PAINTED SURFACES**

The surface should be clean and dry. Follow procedures for cleaning painted surfaces to remove any dirt, chalk, and mildew, on older weathered buildings (see Section I). If repainting a new, un-weathered building (less than 2 years old), wipe area with a lint-free cloth soaked with mineral spirits to remove waxes that have not yet weathered away. Edges or deep scratches should be sanded with No. 400 sandpaper.

Normally, properly cleaned buildings do not require priming. It is, however, possible to encounter buildings where proper adhesion will not take place. This situation is most frequently encountered on new, un-weathered painted surfaces. It is recommended that a recoat ability

test be run. Simply coat a small test area with paint and allow it to dry overnight. Using a strip of scotch tape or duct tape, firmly smooth down about three inches of the tape to the repainted surface while holding the remaining free end of the tape. Rapidly pull the tape off, attempting to remove the new coat of paint with it. If paint is removed with the tape, it indicates that a primer must be used. Consult a paint supplier for further recommendations.

Another test to confirm recoat ability is to rub the panel surface with a cloth saturated with Xylol or Enjay 100 or equivalent. If a film is partially removed, as evidenced by paint on the cloth, primer is not required. If surface is not softened, primer must be used.

### 3. SURFACE PREPARATION FOR GALVANIZED OR ALUMINUM-ZINC COATED SURFACES

Galvanized parts and components may be field painted with interior or exterior commercial paints by using either pretreatment solutions or self-etching commercial paints. Regular paints will not adhere to untreated zinc-coated surfaces, and will chip and peel when applied directly to the alkaline surface.

In addition to having good protective properties in the atmosphere, aluminum-zinc alloy sheeting has a pleasing, distinctive, spangled appearance. If desired, it can be painted with many of the paints which are recommended for galvanized sheet. As with painting any surface, good coating practices should be observed when painting aluminum-zinc alloy or galvanized material. The areas to be painted should be dry, and clean of soil, grease, oil or other contaminants. We suggest that specific paints be discussed with your paint suppliers and their recommendations followed.

Common topcoats that may be used are as follows:

- Zinc Dust-Zinc Oxide in Oil Primers – These have been used with good success over galvanized for many years and are available from many paint companies, as Federal Specifications TT-P-641, Type 1, or in proprietary formulations.

- Outdoor Acrylic Latex Paints – These are widely available as off-the-shelf items from many paint suppliers, can be obtained in a variety of colors and require no topcoat.
- Butyral Wash Primers – Wash primers are applied in very thin films, about 0.3 mil, to promote the adhesion of topcoats. They are never used by themselves and require topcoating for protection, as well as for appearance.
- Epoxy Primers – These are usually supplied in two containers. The contents of the containers are mixed before use.
- Asphaltic Paints – Asphaltic paints are heavy-duty paints and are usually applied in thick coats, 20 to 30 mils. They are used for corrosive conditions, such as flat pitched roofs, where water can accumulate.

## SECTION 3 – EXTENDING BUILDING SERVICE LIFE

### A. ROOF TRAFFIC

Roof traffic should be kept to a minimum when walking directly on roof panels, as this may disturb sealant joints or cause fastener slotting.

Where there is not a service walkway, stepping in the “flat” of the panel and directly over or near roof purlins is advised. Walking on major corrugations may damage the panel.

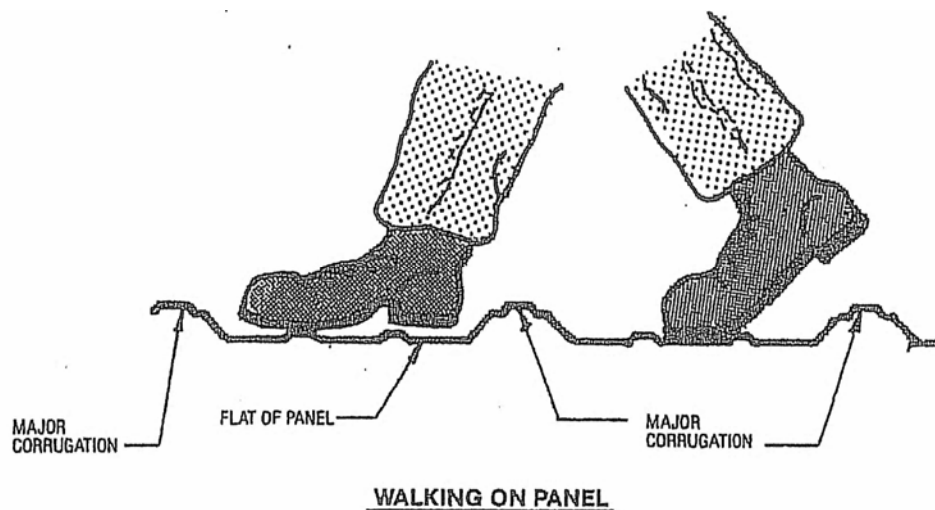

## **B. MECHANICAL EQUIPMENT LOCATED ON ROOF**

Any type of mechanical equipment such as air conditioners, heaters, roof hatches, etc., that would require maintenance or repair from time to time should have a safe service walkway platform located close by. The walkway should be elevated above the roof panel to prevent damage to the roof finish, joint sealant and fasteners.

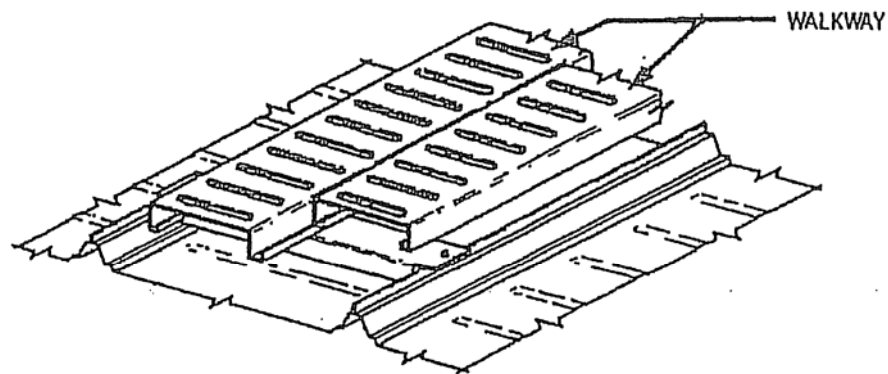

WALKWAY PLATFORM

## **C. SNOW REMOVAL**

Structures of any type are designed for specific loadings. When an above average snowfall occurs, removing snow and ice buildup off the roof structure keeps deflections to a minimum. Failure to do this can result in an overload condition and cause serious damage to your building. We strongly urge you to remove the snow to avoid this occurrence when repeated accumulation is expected. It is also recommended that a structural engineer be consulted before snow removal is initiated.

For more information regarding snow removal, we recommend that you consult the Snow Removal Section of the MBMA Manual (Appendix 9). Snow should be removed in as balanced a manner as is possible. Care should be taken to prevent damage to the roof panels, any mechanicals and fasteners. Metal tools should not be used, and snow blowers are not advisable. When possible, it is recommended that snow be removed without personnel getting on the roof (through the use of draglines, etc.).

If skylights or light transmitting panels are present in your roof, the snow you are in the process of removing may conceal their location. Extreme care should be exercised when working in the area of the skylights/light transmitting panels.

DO NOT STEP DIRECTLY ON SKYLIGHTS/LIGHT TRANSMITTING PANELS OR IN THE AREA ADJACENT TO A SKYLIGHT/LIGHT TRANSMITTING PANEL.

It is very important to recognize that a proactive approach to protecting your building from the excessive acts of nature is the responsibility of the owner.

#### **D. TRAFFIC PROTECTION**

Wall panels, overhead doors, framed openings, walk-doors, etc., should be protected from impact damage caused by motor vehicles and driveways too close to the building corners. Framed openings and doorways without bumper posts are prime targets for damage. Parking curbs set a safe distance from the building in parking lot areas will protect wall panels from damage. Also, canopies located over driveways should be clearly marked for clearances to prevent damage.

Damaged roof or wall panels can be replaced, but due to the various complexities of the situation, this procedure should be referred to a qualified Star Builder for assistance.

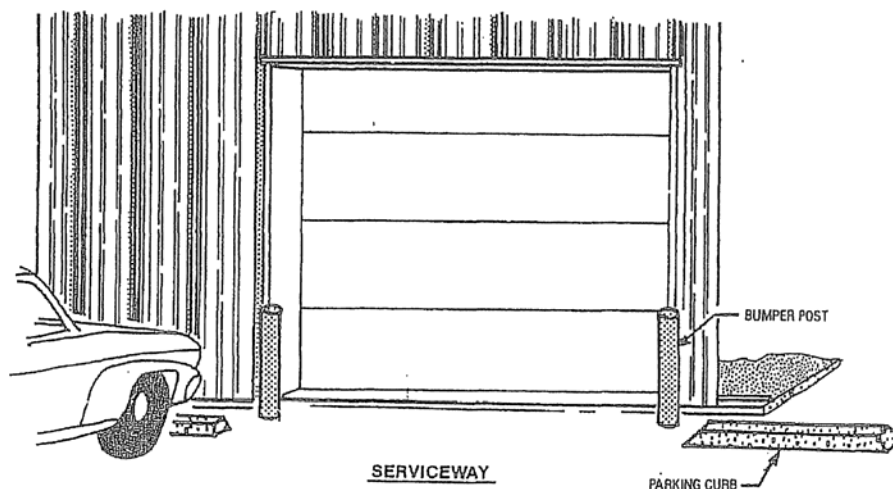

## **E. CONDENSATION**

Excessive moisture resulting from condensation can be common to all types of construction. Condensation occurs when an exposed interior surface is colder than the dew point of the surrounding inside air. This moisture may be visible on the inside surface of the building structure and/or concealed between the metal sheets and the insulation. Because of steel's ability to conduct surrounding temperatures, consideration should be given to proper insulation thickness with a good vapor barrier backing. Installing insulation with a suitable vapor barrier alone may not be adequate to control condensation, particularly in areas of high-humidity occupancy such as kitchens, laundries or rest rooms. Proper ventilation is also essential. Both intake and exhaust ventilation should be provided to change the volume of air. The added expense of this system, along with heating the air, could be far less than the problems caused by condensation and the resulting corrosion.

## **F. ADDITIONAL LOADS**

Items such as sprinkler systems, mechanical equipment, cranes, hoists, partitions, curtain walls, soffits, etc., which are to be supported by the Star building components and were NOT included in the original design will apply additional loads to the building. Addition of any such items should be referred to a structural engineer for a design analysis, as this would not be a part of your original building warranty.





**STAR BUILDING SYSTEMS**

AN NCI COMPANY

8600 South Interstate 35  
Oklahoma City, OK 73149

1-800-879-7827